

1/2-inch Miniature Color Camera

SI-C600N/SI-C600P

OPERATING MANUAL

For Customer Use :

Please record the model No. and the serial No. in the spaces provided below. These numbers located on the bottom of the camera. Retain this information for future reference.

Model No. _____ Serial No. _____

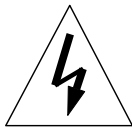

CAUTION

**RISK OF ELECTRIC SHOCK
DO NOT OPEN**



CAUTION : TO REDUCE THE RISK OF ELECTRIC SHOCK, DO NOT REMOVE COVER (OR BACK). NO USER SERVICEABLE PARTS INSIDE. REFER SERVICING TO QUALIFIED SERVICE PERSONAL.

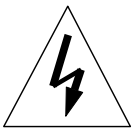

This lightning flash with arrowhead symbol is intended to alert the user to the presence of uninsulated "dangerous voltage" within the product's enclosure that may be of sufficient magnitude to constitute a risk of electric shock to persons.



This exclamation point symbol is intended to alert the user to the presence of important operating and maintenance (servicing) instructions in the literature accompanying the appliance.

Due to design modification, data given in this instruction book are subject to possible change without prior notice.

WARNING :

TO PREVENT THE RISK OF FIRE OR ELECTRIC SHOCK HAZARD, DO NOT EXPOSE THIS CAMERA TO RAIN OR MOISTURE.

Information for USA

This device complies with Part 15 of the FCC Rules. Changes or modifications not approved by COSTAR could void the user's authority to operate the equipment.

Thank you for purchasing this color video camera. Before using this camera, please read this operation manual carefully to obtain the best result and keep this manual for future reference.

CONTENTS

SAFETY INSTRUCTIONS	3	Camera ID	19
PRECAUTIONS	4	Sync	20
FEATURES	5	Language	20
NAME AND FUNCTIONS	6	Camera Reset/ Save All	21
MENU SYSTEM	9	INSTALLATION (LENS)	22
Menu Description	10	Mounting a lens	23
Setup Menu	11	Back-focus adjustment	24
Lens	11	Lenses that can be used	25
Shutter/AGC	12	INSTALLATION (CAMERA)	26
White Balance	13	Installation	26
Back Light	14	CONNECTIONS	27
Picture Adjust	15	SPECIFICATIONS	28
ATR	15	SUPPLIED ACCESSORIES	29
Motion Detection	16	MEMO	30
Privacy	17		
Day/Night	17		
Noise Reduction	19		

SAFETY INSTRUCTIONS

1. Read Instructions

Read all of the safety and operating instructions before using the product.

2. Retain Instructions

Save this instructions for later use.

3. Cleaning

Unplug this appliance from wall outlet before cleaning. Do not use liquid cleaners or aerosol cleaners. Use a damp cloth for cleaning.

4. Attachments

Do not use attachments not recommended by the appliance manufacturer as they may cause hazards

5. Water and Moisture

Do not use this product near water or moisture. (For example, near a bathtub, wash bowl, kitchen sink, or laundry tub, in a wet basement, or near a swimming pool, etc.)

6. Installation

Do not place this product on an unstable cart, stand, or table. The product may fall, causing serious injury to a child or adult, and damage to the product.

Use only with a cart or stand recommended by the manufacturer, or sold with the product.

Mounting are should follow the manufacturer's instructions, and should use a mounting accessory recommended by manufacturer.

7. Moving

Product and cart combination should be moved with care. Quick stops, excessive force, and uneven surfaces may cause the product and cart combination to overturn.



8. Ventilation

Slots and openings in the cabinet and the back or bottom are provided for ventilation, and to insure reliable operation of the product and to protect it from overheating, and these openings must not be blocked or covered.

The openings should never be blocked by placing the product on a bed, sofa, rug, or other similar surface. This product should not be placed in a built-in installation such as a book-case unless proper ventilation is provided.

9. Power source

This product should be operated only from the type of power source indicated on the marking label. If you are not sure of the type of power supplied to your home, consult your dealer or local power company.

PRECAUTIONS

Operating

- Before using make sure of power supply and connection of video output. Power supplied without voltage stabilization or the voltage maintained at $12\text{VDC} \pm 10\%$ may cause damage.
- While operating, if any abnormal condition or a malfunction is observed, stop using the camera immediately then call your local dealer.

Handling

- Do not disassemble the camera and never touch parts inside the camera.
- Do not drop the camera or subject it to shocks and vibrations to avoid possible damage.
- When attaching or removing the lens, handle with care moisture and dust does not enter the camera.
- Do not shoot any source of bright light. If the object contains very bright areas, bright vertical or horizontal lines may appear on the screen. This is called "smear", a phenomenon which often occurs with solid-state pickups, and is not a malfunction.

Installation and storage

- Do not point the camera at the sun. This could damage the camera whether it is operating or not.

- Do not install the camera where the temperature could exceed the allowable range. Be sure the ambient temperature is less than $40\text{ }^\circ\text{C}$ in installations intended for long term continuous operation.
- Avoid installing in a humid or dusty place.
- Avoid installing in places where there is radiation. This could damage sensor and other components and cause a malfunction.
- Avoid installing in places where there are strong magnetic fields and electric signals.
- Avoid installing in places where the camera would be subject to strong vibrations.
- Never expose the camera to rain and water.

Cleaning

Turn the power off and wipe off the dirt with a dry soft cloth. If it is extremely dirty, use furniture cleaning tissue. Do not use alcohols, petroleum distillates, liquid cleaners or sprays.

Daily check

Make daily check for proper operation for surveillance use. In order to maintain normal operation, the output of camera should be checked by user everyday for a clear and focused picture.

FEATURES

High sensitivity

1/2" 412,000 pixels CCD with on-chip micro lenses and low noise digital signal processing circuit provide maximum sensitivity down to $0.05\text{ lux} @ \text{F1.2,50IRE}$.

High quality image

- High resolution, high sensitivity design for a horizontal resolution of 540TV lines.
- High quality image is obtained by digital signal processing with optimization of control program and image correction algorithm.

Back Light (BLC & HLC)

When strong light entering the scene background such as from a spotlight or window, back light compensation function automatically adjust the video level so as to preserve visibility in important sections of the image.

White Balance

Seven white balance control modes can be selected according to conditions.

Iris function

Provide a drive output for video iris lens and DC iris lens. Also built-in electronic shutter to allow 8 shutter speeds up to $1/100,000\text{sec}$.

CCD iris function to automatically set the brightness of the picture by changing the shutter speed of the camera according to the incident light when using a manual iris lens.

Other versatile functions

- Camera ID function of up to 24 characters.
- Motion detection, Noise reduction and Privacy functions are provided.
- Picture adjustment for Mirror, Brightness, Contrast, Sharpness, HUE, Gain..
- Use either C or CS mount lenses.

Note : You must install a UPS system for safe operation in order to prevent damage caused by an unexpected power stoppage.



NAME AND FUNCTIONS

Lens mount

Mount for installing the lens. C-mount lens can be used when C-mount adapter is attached, and CS-mount lens can also be used when it is removed.

Back-focus screw

A screw is provided to fix the lens mount. See page 24.

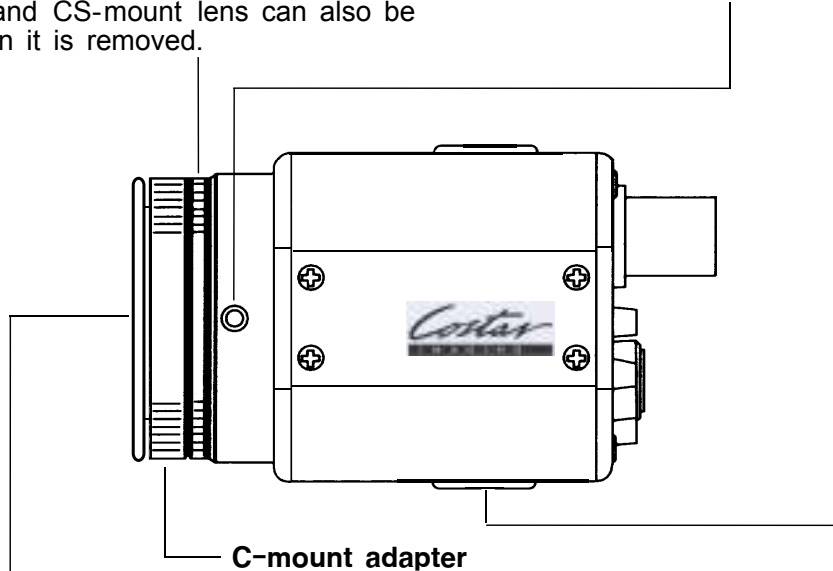

Lens mount cap

Be sure to cap the lens mount when the lens is not mounted.

C-mount adapter

To mount a C-mount lens. And remove to mount a CS-mount lens. Turn counterclockwise to remove it. Also refer to page 23.

Tripod mounting base

Mounting base for installing the camera.

6

Power indicator

Lights up when the camera is powered.

Video output connector

BNC connector that outputs a composite video signal.

Setup buttons

When use setting up and adjusting the camera with reference to the on-screen menu. See page 9.

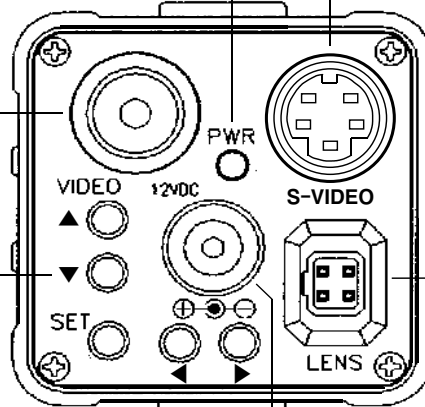

S-VIDEO connector

Output connector for separated Y/C video signal. Connect to the S-VIDEO input connector of video monitor, See page 22.

Lens connector

When using an auto-iris lens, connect the lens cable to this connector. See page 8.

Power input terminal

Connect to a DC12V power power source. (Be sure not to connect the power source until all other connections are completed.)

7

Lens Connector

DC type lens ;

Connect the lens cable of a DC (galvanometric) type lens. If the plug on the cable is of a different type, replace it with the provided 4-pin iris plug.

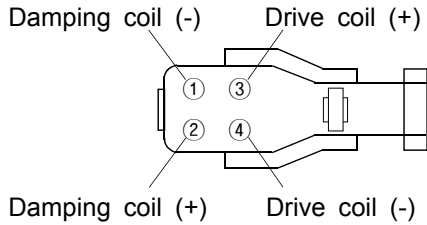

Pin Assignment : DC type (4-pin)

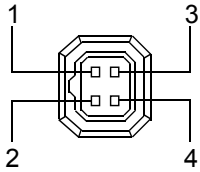

Pin No.	Signal
1	Damping coil (-)
2	Damping coil (+)
3	Drive coil (+)
4	Drive coil (-)

After installing the connector plug, connect it to the lens connector on the rear panel of camera.

8

MENU SYSTEM

GENERAL

The menu system can activate all the features and option of the camera.

The menus are superimposed on the image displayed on the screen. The commands can open other menus, toggle options, or change variable parameters.

MENU OPERATION

Five rear panel Setup buttons are used to shift the cursor and select items from the menus.

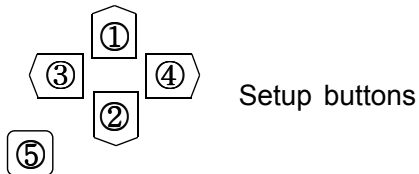

- ① Up button : Shift the cursor upwards.
- ② Down button : Shift the cursor downwards.
- ③ Left button : Shift the cursor toward the left.
- ④ Right button : Shift the cursor toward the right.
- ⑤ Set button : To display the main menu or check the setting and proceed to the next item.

The camera settings and adjustments can be changed to accommodate usage conditions. When connected to a monitor, convenient on-screen menus facilitate checking and changing the settings and adjustments.

A brief help lines is often presented on the screen below the list of commands.

The complete set of current parameters is saved, and will be loaded each time turn on the camera until the next time change the setup.

The setting menus are illustrated on the next page.

9

Menu Description

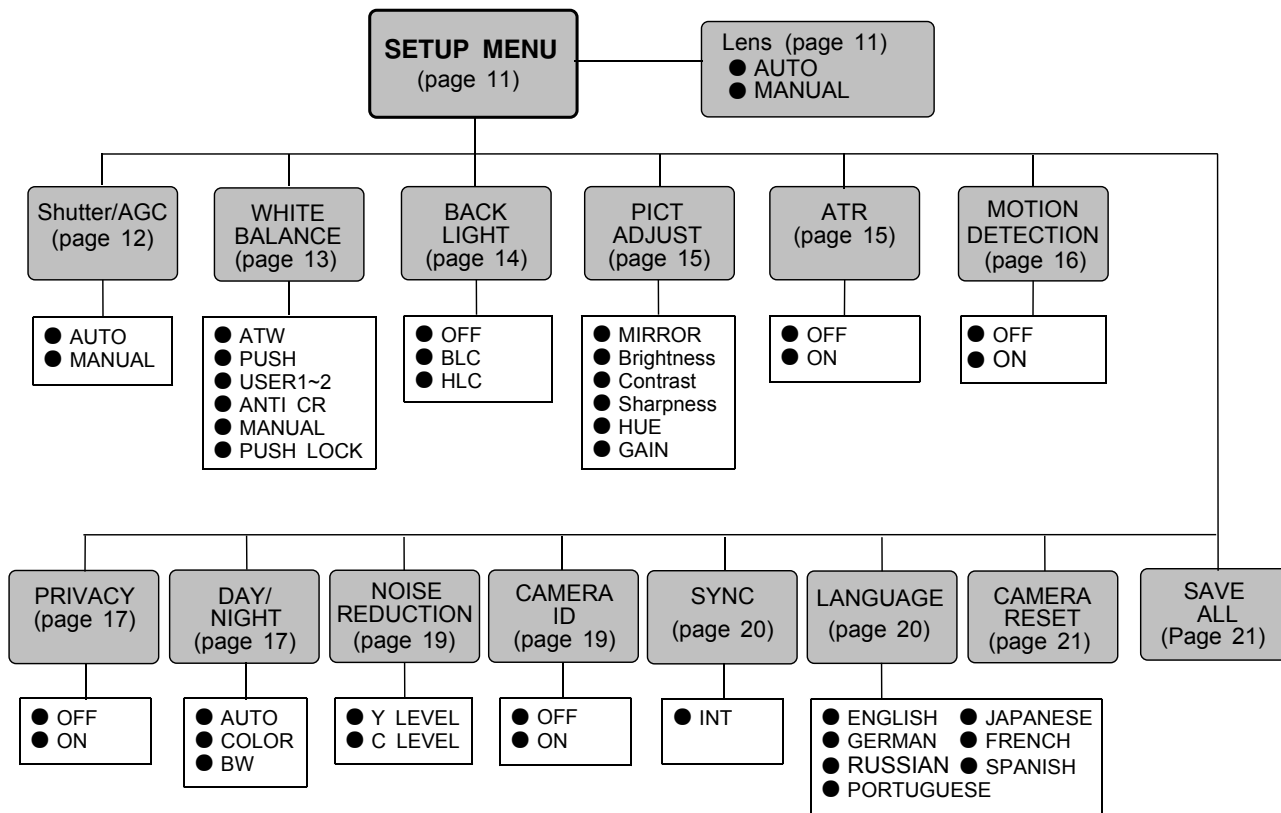

10

SETUP MENU

- 1) Press the Set button to display the Setup menu on the monitor screen.
- 2) Check the present settings at the Setup menu.

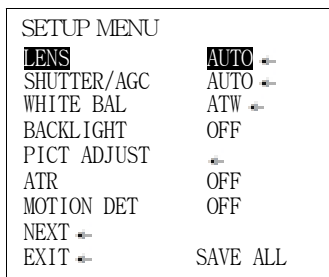

Setup menu

- 3) If changes are unnecessary, shift the cursor to the EXIT position and press the Set button to return the normal video screen.
- 4) When a setting is changed by pressing the Setup buttons, the new setting is stored in the internal memory by pressing the Set button with position the cursor at SAVE ALL.

Afterwards, when the camera power is cut off and returned, operation proceeds at the most recent settings.

LENS

- 1) Press the Set button to display the Setup menu.
- 2) Position the cursor at LENS and press the left or right button to select the Lens mode.

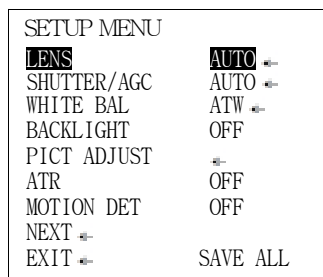

- 3) Position the cursor at AUTO and press the Set button to setting for Auto Iris Lens.

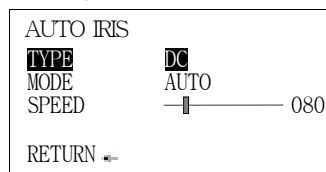

- 4) Press the Left, Right, Up, Down button to setting the Lens.

After setting, position the cursor at RETURN and press the Set button to return to Setup Menu.

11

SHUTTER/AGC

- 1) Press the Set Button to display the Setup menu.
- 2) Position the cursor at SHUTTER/AGC and press the left or right button to select the Auto mode or Manual mode setting.

AUTO Mode

When using the Auto Iris lens, the brightness of the picture image will be controlled by setting the Brightness level.

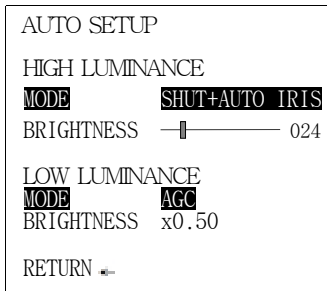

In SHUT+AUTO IRIS mode, shutter speed is automatically varied according to the incident light.

The brightness indicates DC level of DC lens in High Luminance mode.

In Low Luminance mode, brightness indicates AGC level.

MANUAL Mode

When using the Manual Iris lens, the brightness of the picture image will be controlled by setting the shutter level.

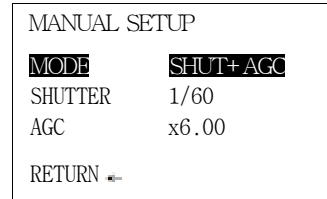

In Manual mode, Shutter and AGC level will be changed as follows.

Shutter : 1/60 to 1/100,000sec (8 stage)
AGC level : 6dB to 44.8dB (8 stage)

Note : Outdoor illumination levels may exceed 150,000 lux, which is outside the range that can be controlled by the electronic shutter. For proper operation of electronic shutter, If illumination levels exceed 10,000 lux, use a auto-iris lens.

WHITE BALANCE

- 1) Press the Set button to display the Setup menu.
- 2) Position the cursor at LENS and press the left or right button to select the white balance mode.

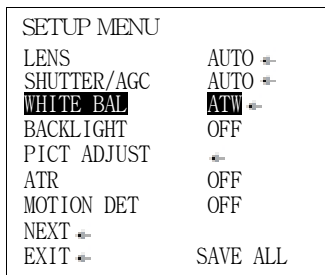

Seven white balance control modes can be selected according to conditions.

ATW :

Automatically tracks the changes in the color temperature, and adjusts the white balance.

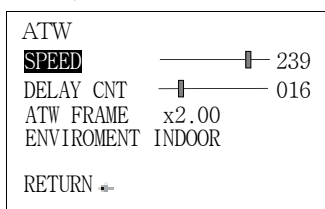

SPEED : Adjusts the pull-in speed of ATW.

DELAY CNT : Sets the time-based hysteresis of ATW.

ATW FRAME : Sets the pull-in frame magnification.

ENVIROMENT : Sets the pull-in frame of ATW. (indoor or outdoor)

PUSH :

Adjusts the white balance regardless of the subject condition.(Pull-in mode)

USER1 :

Manually adjusted white balance by User mode1.

USER2 :

Manually adjusted white balance by User mode2.

ANTI CR :

Minimizes the color changes(color rolling) over long periods caused by very small differences between the flicker frequency of non-inverter fluorescent lights and the drive frequency of the image sensor devices.

MANUAL :

Function allows the white balance to be adjusted manually following the black body radiation curve. The R gain is adjusted automatically in tandem with the up/down setting of the B gain.

PUSH LOCK :

Function for locking the WB gain after PUSH(pull-in) control and shutting down the pull-in control.

BACKLIGHT

Two backlight modes can be selected according to conditions.

SETUP MENU	
LENS	AUTO ←
SHUTTER/AGC	AUTO ←
WHITE BAL	ATW ←
BACKLIGHT	BLC
PICT ADJUST	←
ATR	OFF
MOTION DET	OFF
NEXT ←	
EXIT ←	SAVE ALL

HLC Mode

High light compensation is a function that improves the visual recognition of license plates and other such objects by suppressing or marsking strong light sources(such as headlights of automobiles) in dark places.

BLC Mode

The backlight compensation function provides compensation by increasing the brightness of the overall screen so that subjects being shot with a loss of dark detail due to backlight will have just the right brightness level.

The excessive front lighting compensation function provides compensation by reducing the brightness of the overall screen so that subjects being shot which are overexposed due to excessive front lighting will have just the brightness level.

PICTURE ADJUST

- 1) Press the Set button to display the Setup menu.
- 2) Position the cursor at PICT ADJUST and press the Set button to adjust the video output signal.

PICT ADJUST	
MIRROR	OFF
BRIGHTNESS	▬ 000
CONTRAST	▬ 128
SHARPNESS	▬ 128
HUE	▬ 128
GAIN	▬ 128
RETURN ←	

MIRROR : Sets the horizontal flip for the display output.

BRIGHTNESS : Sets the brightness of video output signal.

CONTRAST : Sets the contrast of video output signal.

SHARPNESS : Sets the sharpness of video output signal.

HUE : Sets the HUE(color) of video output signal.

GAIN : Sets the chroma gain of video output signal.

ATR (Adaptive Tone Reproduction)

ATR function provides gradation compensation to improve the contrast of subjects whose gradation has been lost in cases where, for instance, both low-luminance areas and high-luminance areas exist in the same picture.

The ATR function improves the visibility of the entire picture by providing the optimum gradation compensation for the image in one field based on the luminance information.

- 1) Press the Set button to display the Setup menu.
- 2) Position the cursor at ATR and press the left or right button to ATR mode ON.

SETUP MENU	
LENS	AUTO ←
SHUTTER/AGC	AUTO ←
WHITE BAL	ATW ←
BACKLIGHT	OFF
PICT ADJUST	←
ATR	ON
MOTION DET	OFF
NEXT ←	
EXIT ←	SAVE ALL

MOTION DETECTION

By using the motion detection function, it is possible to create surveillance cameras which are capable of detecting moving objects.

The motion detection function identifies motion and outputs motion information when the difference in brightness exceeds a specific level between frames (2VD).

- 1) Press the Set button to display the Setup menu.
- 2) Position the cursor at MOTION DET and press the Set button to setting the motion detection function.

MOTION DET	
DETECT SENSE	111
BLOCK DISP	OFF
MONITOR AREA	ON
AREA SEL	1/4
TOP	000
BOTTOM	000
LEFT	000
RIGHT	000
RETURN	←

DETECT SENSE : Sets the motion detection sensitivity.

BLOCK DISP : Control of the motion detection block display.

MONITOR AREA : Sets whether to use the monitoring frames.

AREA SEL : Selects the monitoring frame to be set.

TOP : Sets the top side of the monitoring frame.

BOTTOM : Sets the bottom side of the monitoring frame.

LEFT : Sets the left side of the monitoring frame.

RIGHT : Sets the right side of the monitoring frame.

16

PRIVACY

This function is to make lest the specific part should be seen on the screen.

- 1) Position the cursor at Privacy and press the left, right button to set Privacy ON.
- 2) Press the Set button to enter the Privacy setup.

PRIVACY	
AREA SEL	1/4
TOP	000
BOTTOM	000
LEFT	000
RIGHT	000
COLOR	1
TRANSP	1.00
MOSAIC	OFF
RETURN	←

AREA SEL : Selects the mask frame to be adjusted.

TOP : Sets the top side of the mask frame.

BOTTOM : Sets the bottom side of the mask frame.

LEFT : Sets the left side of the mask frame.

RIGHT : Sets the right side of the mask frame.

COLOR : Sets the color of the mask frames.

TRANSP : Sets the transparency ratio of the mask frames.

MOSAIC : Sets the mask frame mosaic function.

DAY/NIGHT

Day/Night function improves the camera's sensitivity at night or when the brightness level of the ambient environment is otherwise low by removing the infrared filter and enabling the camera to shoot with the wavelengths of the incident light extending up to the infrared region.

Three Day/Night modes can be selected according to conditions.

- **COLOR**

Day/Night function is set to OFF.

- **B/W**

Night mode established forcibly, and chroma is set to OFF.

- **AUTO**

Day or Night function is automatically identified and controlled according to illumination condition.

SETUP MENU	
PRIVACY	OFF
DAY/NIGHT	AUTO ←
NR	←
CAMERA ID	OFF
SYNC	INT
LANGUAGE	ENGLISH
CAMERA RESET	
BACK	←
EXIT	←
	SAVE ALL

17

AUTO Mode :

- 1) Position the cursor at Day/Night and press the left or right button to change the Day/Night mode.
- 2) Press the Set button only when position the cursor at Auto to adjust the Day/Night function control.

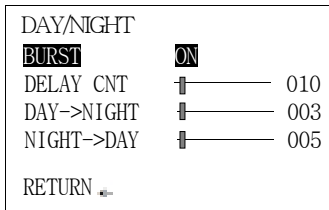

BURST : Selects whether to output the burst signal when the night status has been identified.

DELAY CNT : Sets the Night/Day identification transfer time.

DAY->NIGHT : Sets the threshold for identifying the Night status from the Day status.

NIGHT->DAY : Sets the threshold for identifying the Day status from the Night status.

BW Mode :

- 1) Press the Set button only when position the cursor at BW to adjust the BW mode control.

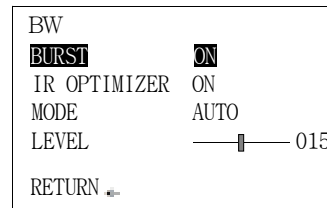

- 2) Press the left/right/up/down button to select a BW mode control.

BURST : Selects whether to output the burst signal when the BW status has been identified.

IR Optimizer Function :

If, when the Night operation mode of the Day/Night function is established, the mode is used together with an external infrared LED light source, excessive front lighting may occur, resulting in over exposure.

The IR Optimizer function makes it possible to minimize this overexposure by optimizing the exposure control during Night operations.

NOISE REDUCTION

Noise reduction is a function that reduces the image noise in order to improve the image quality of the camera.

In particular, it reduces the noise which is generated under low-brightness shooting conditions and other high-gain states.

- 1) Position the cursor at NR and press the Set button to setting the noise reduction function.

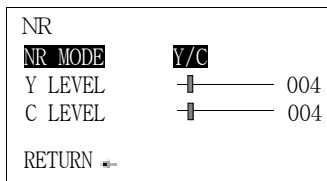

- 2) Press the cursor at NR MODE and press the left or right button to change the NR mode.

Y/C : Y and C filter ON.

Y : Y filter ON.

C : C filter ON.

Y LEVEL : Sets the Y filter strength.

C LEVEL : Sets the C filter strength.

CAMERA ID

When the internal OSD menu display is hidden in the internal mode, it is possible to display the Camera ID on-screen.

Any character string consisting of two rows (vertical) of up to 26 characters (horizontal) on each row can be used for the Camera ID, and it can be displayed at any position on the screen.

- 1) Position the cursor at CAMERA ID and press the Set button to setting the Camera ID.

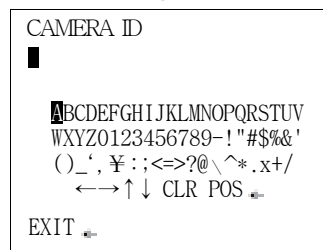

- 2) Press the left/right/up/down button to select a character and press the Set button to camera ID generation.

- 3) Press the Set button to camera ID position set when position the cursor at POS.

- 4) Press the left/right/up/down button to move the camera ID position.

SYNC (Internal Only)

This function is used to display the current synchro- nization mode.

When the line lock mode is being used as the synchronization mode, it is possible to adjust the phase in the vertical direction.

- 1) Position the cursor at SYNC and press the left or right button to select the Sync mode.

SETUP MENU	
PRIVACY	OFF
DAY/NIGHT	AUTO ←
NR	←
CAMERA ID	OFF
SYNC	L
LANGUAGE	ENGLISH
CAMERA RESET	
BACK ←	
EXIT ←	SAVE ALL

- 2) Press the Set button only when position the cursor at LL to adjust the line lock phase.

LL	
PHASE	— — 326
RETURN ←	

Adjusts the phase in the vertical direction when the line lock mode is established.

LANGUAGE

The OSD menu displays support 7 languages ; English, Japanese, German, French, Russian, Spanish and Portuguese.

Position the cursor at LANGUAGE and press the left, right button to select a language.

The menus can be changed in real time in the selected language.

MENU CONFIGURATION	
CONFIDENTIAL	OFF
JOUR/NUIT	AUTO ←
REDUCT BRUIT	←
ID CAMERA	OFF
SYNC	INT
LANGUAGE	FRANCAIS
REINIT. CAMERA	
BACK ←	
QUITTER ←	SAVE ALL

CAMERA RESET

This function initializes all the OSD menu settings together.

Position the cursor at CAMERA RESET and press the Set button to camera reset.

SETUP MENU	
PRIVACY	OFF
DAY/NIGHT	AUTO ←
NR	←
CAMERA ID	OFF
SYNC	INT
LANGUAGE	ENGLISH
CAMERA RESET	
BACK ←	
EXIT ←	SAVE ALL

SAVE ALL

This function is used to save the various settings of the OSD menu in the EEPROM together.

SAVE ALL is always displayed on the bottom line of the top menu.

INSTALLATION (LENS)

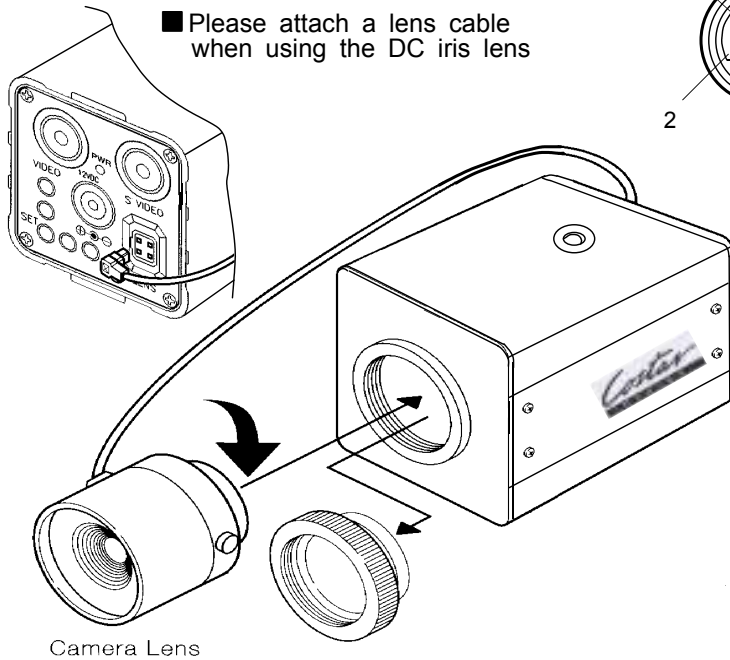

Pin assignment : S-VIDEO connector (4-pin)

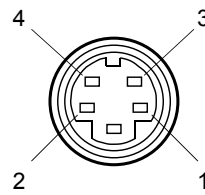

Pin No.	Signal
1	GND
2	GND
3	Y (Luminance, 1Vp-p, 75Ω)
4	C (Chrominance, 0.286Vp-p, 75Ω)

22

Mounting a lens

- ① Remove the lens mount cap from the camera.
- ② Attach or remove the C-mount adapter depending on the lens to be used.
 - If the adapter is attached so tightly that it is difficult to remove, use long-nosed pliers to remove it. Insert the tips of the pliers into the holes with no threads, thus turn to remove. Or a screwdriver can also be used, as shown. Insert M3 screws into the holes so that the screwdriver has something to grip. (Store the C-mount adapter for possible future use.)

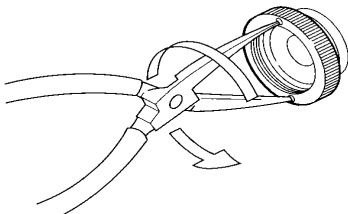

- ③ Attach the lens to the lens mount. Secure it so that it does not become loose.
- ④ If the lens has an auto-iris mechanism, connect the lens cable to the lens connector.
 - When installing a video-iris lens, lens switch should be set to VIDEO position.

- When installing a galvanometric-iris lens, lens switch should be set to DC position.

ADJUSTING AUTO-IRIS LENSES

Make this adjustment after connecting the camera to a power source and a monitor.

- 1) Set AGC mode to off.
- 2) When using a Video type lens :
Adjust the level control on the lens to produce minimum smear and optimum pictures.
- 3) When using a DC type lens :
Adjust the video level control on the main menu to produce minimum smear and optimum pictures.
- 4) Set AGC mode to on
It is recommended that the AGC be used in the "on" mode after adjusting the video level.

23

Back-focus adjustment

When a lens is mounted, adjustment of the back-focus may sometimes be required. Adjust the lens focus ring when the correct focus cannot be obtained.

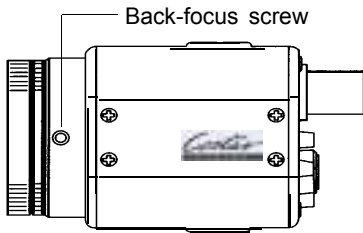

WITH A FIXED-FOCUS LENS

- 1) Fully open the aperture and set the focus ring to "∞" (infinity).
In the case of an auto-iris lens only, shoot a comparatively dark object so that the aperture is fully open.
- 2) Loosen the two back-focus screw with a hex wrench, and turn the lens mount to focus.
- 3) After adjusting the back-focus, tighten the back-focus screw.

Caution : Do not forcibly turn the back-focus screw, as it will cause damage to the camera.



WITH A ZOOM LENS

- 1) Fully open the aperture and set the lens to the maximum tele-photo position. Then turn the focus ring to focus.
In the case of an auto-iris lens only, shoot a comparatively dark object so that aperture is fully open.
- 2) Set the lens to its maximum wide-angle position.
- 3) Loosen the two back-focus screw with a hex wrench, and turn the lens mount to focus.
- 4) After adjusting the back-focus, tighten the back-focus screw.
- 5) Repeat step 1) ~ 3) until the difference between focusing position 1) and 2) becomes smallest.

Caution : Do not forcibly turn the back-focus screw, as it will cause damage to the camera.



Lenses that can be used

- The camera can use C-mount lenses when the C-mount adapter (standard accessory) is installed. When removed, CS-mount lenses can also be used.
- Use a suitable lens for the required area of view. The area of view for different focal length can be obtained using the following formula.

$$\text{Height of the area of view (m)} = \frac{A \times \text{Distance between camera and object (m)}}{\text{Focal length of lens(mm)}}$$

$$\text{Width of the area of view (m)} = \frac{B \times \text{Distance between camera and object (m)}}{\text{Focal length of lens(mm)}}$$

Mounted Lens	1/2" Lens	1/3" Lens
A	4.8	3.6
B	6.4	4.8

Notes : ● "L" in the illustration below should be as shown in the following table. If "L" exceeds the value in the table, it may damage the inside of the camera and correct mounting may be impossible.



Be sure not to attach the C-mount adapter when using a CS-mount lens.

- Lenses designed for color video cameras are recommended.
Lenses designed for B/W cameras may have inferior color reproduction and picture quality. In particular, they are not suitable for use outdoors or in very bright conditions.
When using a lens with an ND filter attached, shooting may not be possible with the minimum required illumination specified.

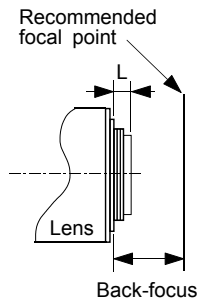

Lens	Back-focus	Distance "L"
C-mount lens*	17.526 mm	Less than 9mm
CS-mount lens**	12.5 mm	Less than 4mm

* With the C-mount adapter attached.

** With the C-mount adapter removed.

INSTALLATION (CAMERA)

Installation

- Camera can be installed on a tripod or a fixing part from the upper plate or the bottom plate by using the camera fixing holes (1/4", 20UNC) on the tripod mounting base. The tripod mounting base has been installed on the bottom plate when shipped from factory. Move the tripod mounting base when installing the camera from the upper plate.
- There are two camera fixing holes on the tripod mounting base. Use the two holes to increase the fixing intensity when installing the camera specially.

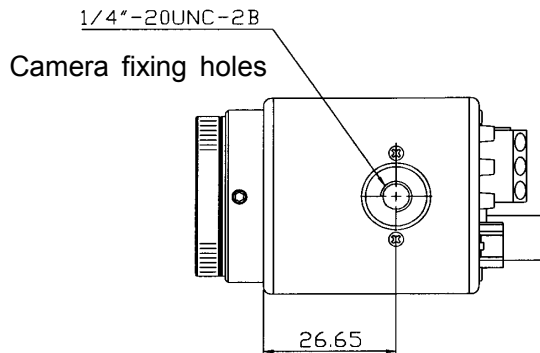

26

CONNECTIONS

Connect the video output of the camera to the video input of a monitor or other equipment. When using a "loop through" connection of two or more monitors, set the 75Ω switch of only the final monitor to on. Determine the type of cable according to the distance of the connected equipment.

- Do not turn any component's power on until all connections are completed.

To Video input connector

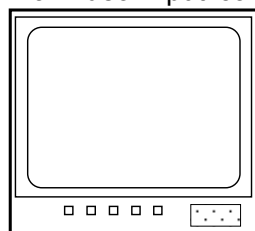

S-Video

Composite Video

To Power input terminal

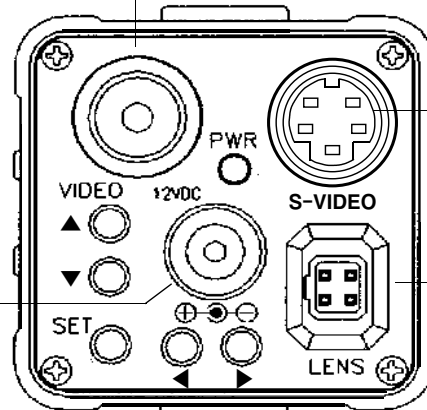
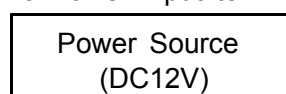

To Lens connector

DC-Iris lens

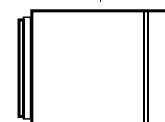

27

SPECIFICATIONS

Signal system	SI-C600N : NTSC SI-C600P : PAL	AGC range	6dB~44.8dB(Manual)
Pickup element	1/2" Sony IT CCD	Shutter speed range	1/60(1/50)~1/100,000sec
Effective pixels		Manual shutter speed	1/60(1/50), 1/120, 1/250, 1/500, 1/1000, 1/5000, 1/10000, 1/50000 sec
SI-C600N	768(H)X494(V)	Video S/N ratio	48dB (AGC OFF)
SI-C600P	752(H)X582(V)	Backlight Compensation	ON/OFF (BLC/HLC selectable)
Chip size	7.4(H)X5.95(V)mm	Text display	ON/OFF (24 alphanumeric character)
Scanning system	2:1 interlace	Privacy	ON/OFF
Scanning frequency		Motion Detection	ON/OFF
SI-C600N	Hor. 15.734kHz / Ver. 59.94Hz	Noise Reduction	Y&C Reduction
SI-C600P	Hor. 15.625kHz / Ver. 50Hz	Day/Night	Auto/Day/BW
Sync system	Internal	Picture Adjust	Mirror, Brightness, Contrast, Sharpness, HUE, Gain
Video output		OSD Language	English, Japanese, German, French, Russian, Spanish, Portuguese
Composite video signal (1Vp-p, 75Ω, unbalanced)		Auto-iris Lens	Coupling coil impedance Damper : 1.2KΩ±10% Drive : 200Ω±10%
Separated Y/C signal (Y;1Vp-p/75Ω, C;0.286Vp-p /75Ω)			
Hor. Resolution	540 TV lines		
Minimum illumination	0.05Lux at F1.2, 50 IRE		
White balance	ATW/Push/ User1/ User2/ Anti CR/ Manual/ Push Lock		
White balance range	2,400K ~ 10,000K		

28

Lens mount	C/CS mount
Camera mount	1/4 Inch -20UNC (Top/ Bottom)
Power requirement	DC12V
Power consumption	2.5 Watt
Operating temperature	-10°C to +50°C (14°F to 122°F)
Operating humidity	less than 85% relative
Storage temperature	-20°C to +60°C
External dimensions	41(w)x41(h)x51.6(d) mm 1.6(w)x1.6(h)x2.1(d) inch
Weight	140g (0.31 lbs)

Notes : If used continuously, be sure to operate less than 40°C for long term stable performance.

SUPPLIED ACCESSORIES

Lens mount cap	1
C-mount adapter	1
Operation manual	1

- The fuse must be replaced only by a qualified service technician.
- The lens mount cap and C-mount adapter are attached when supplied.

Notes :

- Design and specifications are subject to change without notice.
- This color video camera is designed to output video signals conforming to the NTSC (PAL) standard, so that it cannot be used with video recorder or color monitors which use color systems other than NTSC (PAL).

MEMO